



4048P-HYB

15 cu ft POLY SWIVEL HYBRID DUMP CART

U.S. Patent No. 8,496,298



**READ AND FOLLOW ALL SAFETY RULES AND OPERATING
INSTRUCTIONS BEFORE USING THIS EQUIPMENT**

Safety Rules



This is the safety alert symbol. It is used to alert you to potential personal injury hazards. Obey all safety messages that follow this symbol to avoid possible injury or death.

Read and understand all safety rules and operating instructions before using this tractor/ATV/UTV attachment.

Follow all safety rules and operating instructions provided by your vehicle's manufacturer when using attachment.

Never allow children or untrained persons to operate vehicle or attachment.

Do not exceed the vehicle manufacturer's towed weight limit.

Reduce vehicle speed and allow extra stopping distance when towing heavy loads.

Reduce vehicle speed and towed weight when operating on slopes.

Operate up and down slopes, never across the face of slopes.

Do not carry passengers on vehicle or attachment.

Avoid sudden turns or maneuvers.

Do not tow attachment on public roadways.

Do not remove warning decals from product.

Check product for worn, loose, or damaged parts before each use. If any damage is present, repair the product before using.

Check product for loose or missing fasteners before each use. Tighten or replace fasteners as needed before using.

Do not exceed vehicle speed of 20 miles per hour when towing Dump Cart.

Do not exceed Dump Cart rated weight capacity of 1250 pounds.

Warranty

IF YOU ARE MISSING PARTS DO NOT RETURN TO STORE

Email cs@ohiosteel.com or call 1-800-652-2321, ext. 212

Attach Receipt Here:

Before you call, please email our customer service team at cs@ohiosteel.com with the following:

1. A description of the issue you are having
2. Photos of the issue that include an overall view and detailed view from multiple angles
3. If applicable, a short video showing the issue

Replacement Parts:

You can place your parts order online at ohiosteel.com/partsstore

- You can also reach our Customer Service Department at 1-800-652-2321, ext. 212
- If you are ordering replacement part(s) for your product, please note that some parts are only available as a repair kit.

If this product fails due to a defect in material or workmanship within THREE YEARS from the date of purchase, we will at our option, only with receipt of purchase, repair or replace it free of charge. This warranty excludes tires, bushings, and bearings which are expendable and become worn during normal use.

This warranty does not cover:

- Repairs necessary because of operator abuse or negligence.
- Equipment used for commercial or rental purposes.
- Paint that is worn or faded due to normal use or exposure.

To arrange for product repair visit ohiosteel.com/customer-support and fill out the warranty repair form. You can also call 1-800-652-2321, ext. 212 to speak to our Customer Service Team

This warranty gives you specific legal rights, and you may also have other rights which may vary from state to state. This warranty applies only while this product is in use in the United States.

Carton Contents

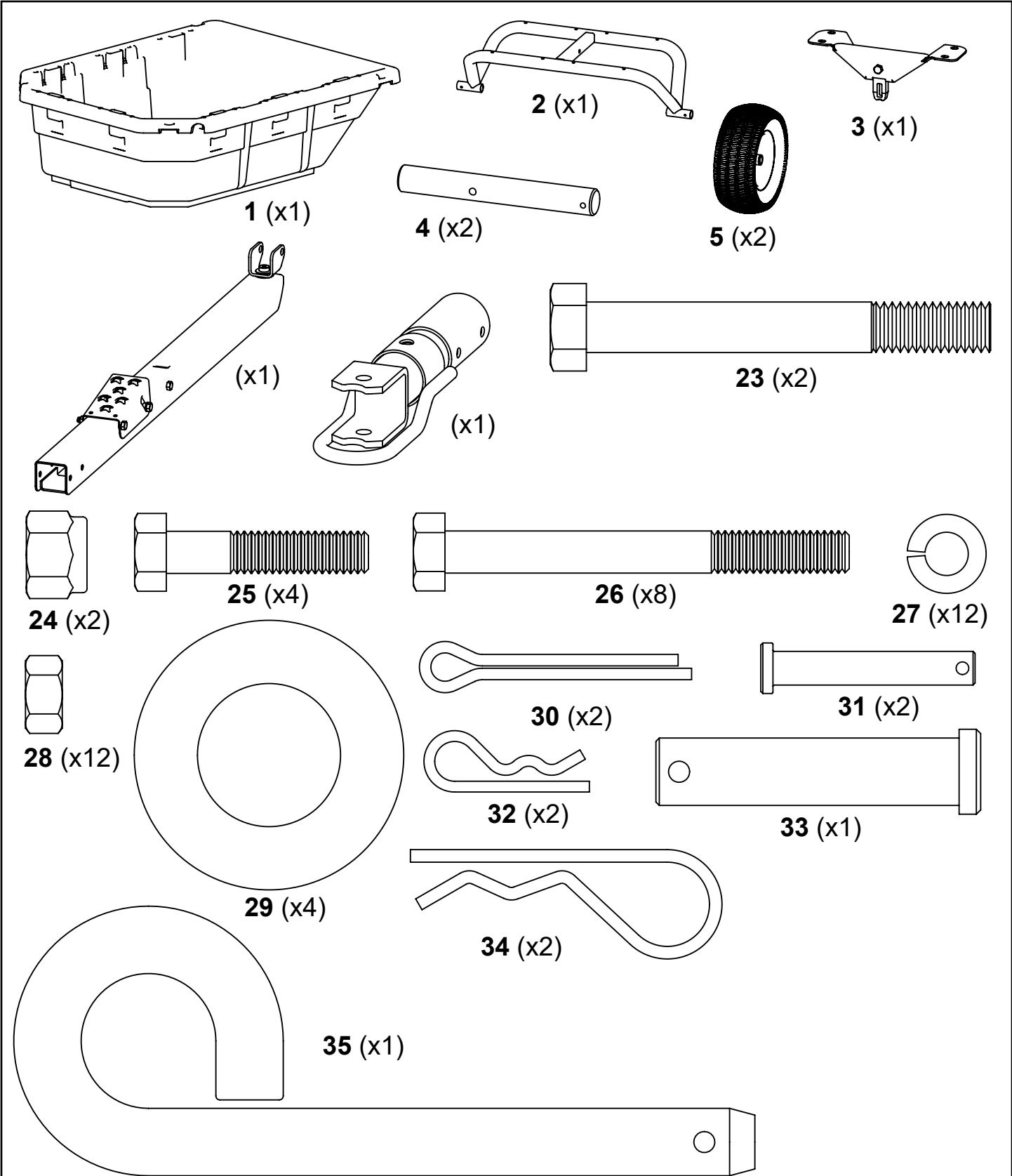

TOOLS REQUIRED FOR ASSEMBLY:

- 1/2" Wrench and Socket
- 9/16" Wrench and Socket
- Needle-Nose Pliers
- Grease Gun

Assembly Instructions

1

Hold Poly Body (1) on side as shown. Insert Hex Bolts (25 & 26) as shown.

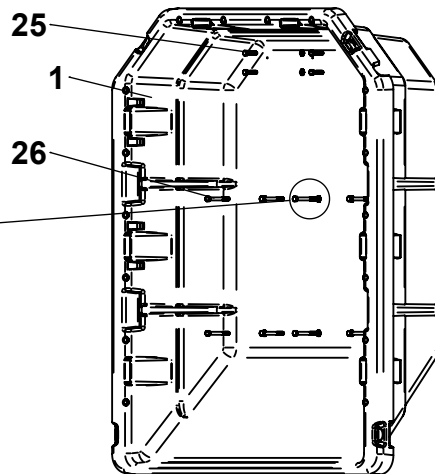
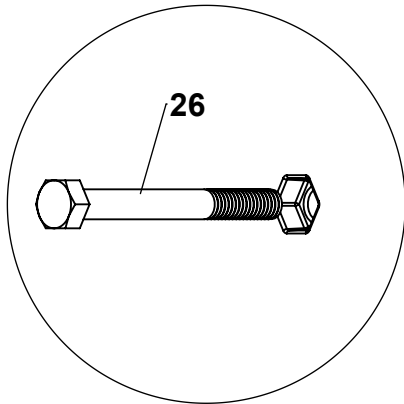

2

Flip Poly Body (1) to expose bolts.

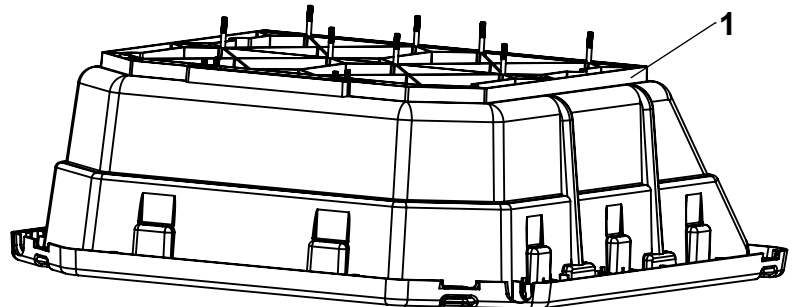
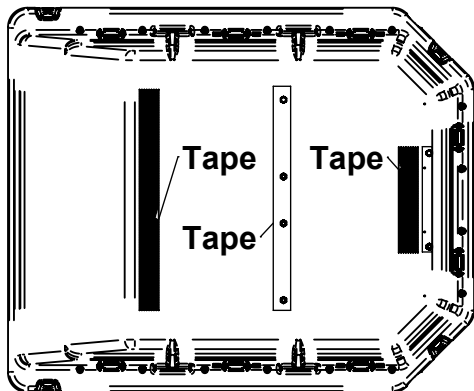

TIP: Bolt heads can be secured with tape to aid in assembly.

3

Install Undercarriage (2) over top of Hex Bolts. Install Lockwasher (27) and tighten Hex Nuts (28) onto Hex Bolts.

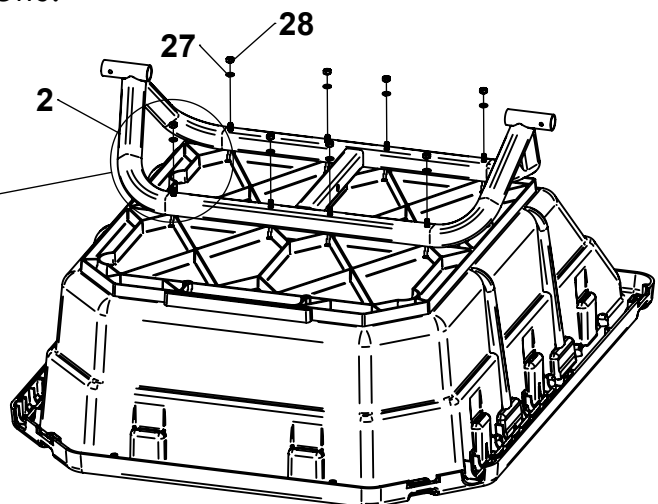
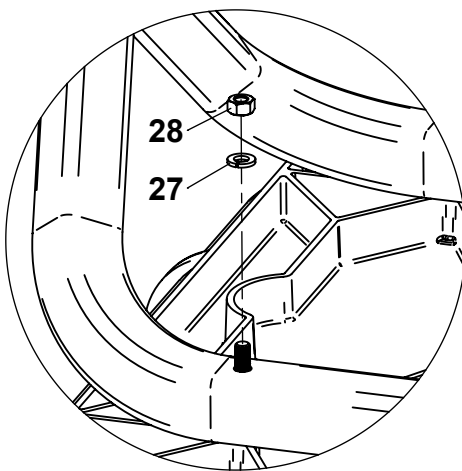

Assembly Instructions

4

Attach Front Support (3) to Poly Body (1). Install Lockwasher (27) and tighten Hex Nuts (28) onto Hex Bolts.

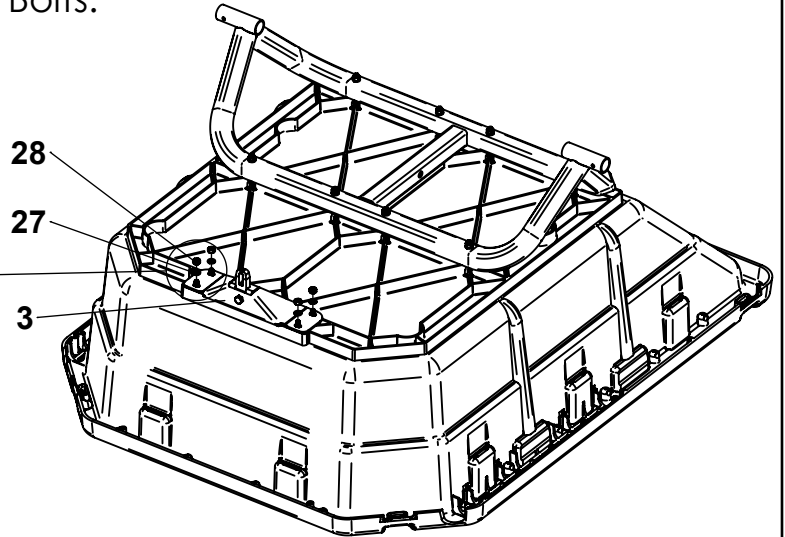
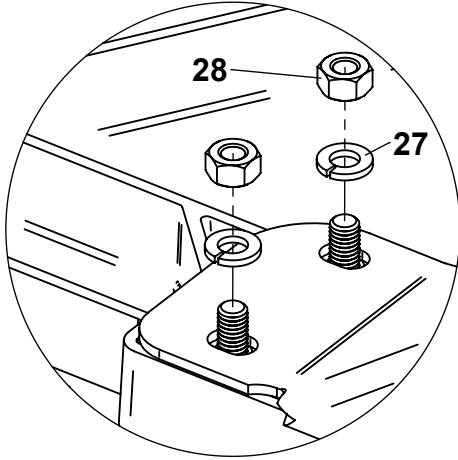

5

Insert Stub Axles (4) into Undercarriage (2) and secure with Clevis Pins (31) and Hairpin Cotter Pins (32).

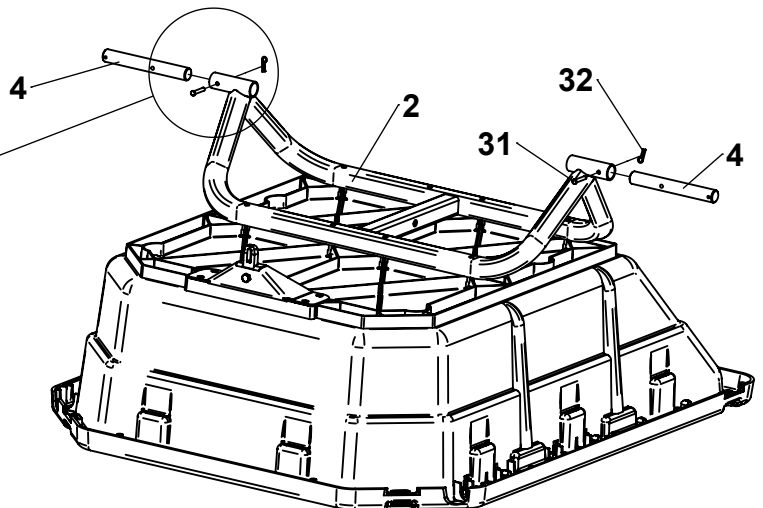
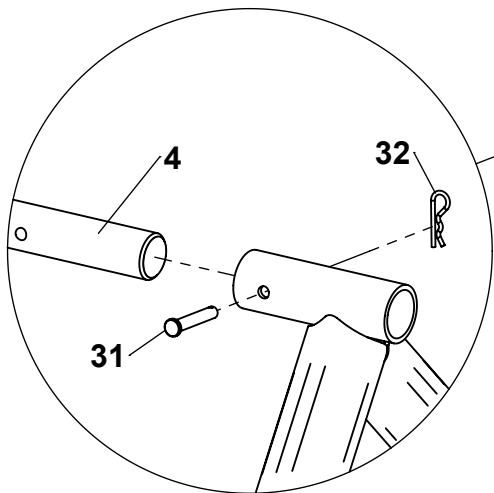

6

Slide Washers (29) and Wheels (5) onto Stub Axles (4). Install Cotter Pins (30). Bend legs of Cotter Pins to secure.

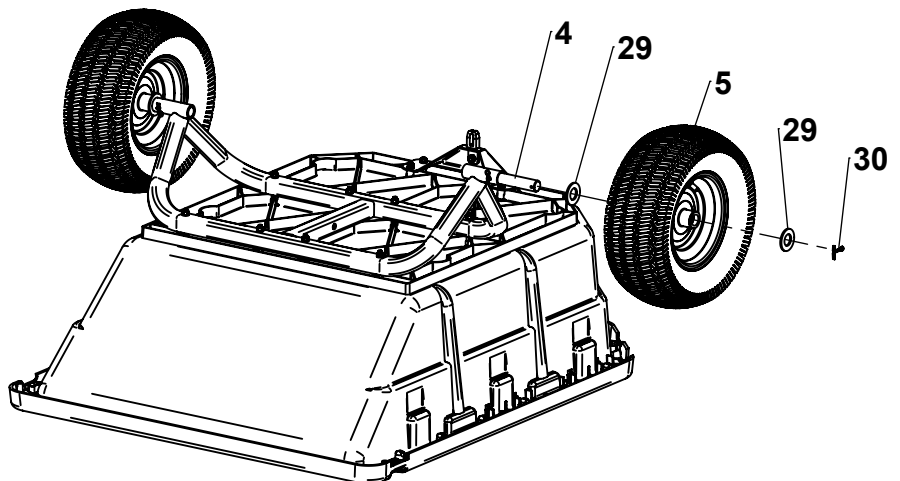

Assembly Instructions

7

Align holes in Swivel Clevis and Undercarriage and install Clevis Pin (33) as shown. Secure Pin with Hairpin (34).

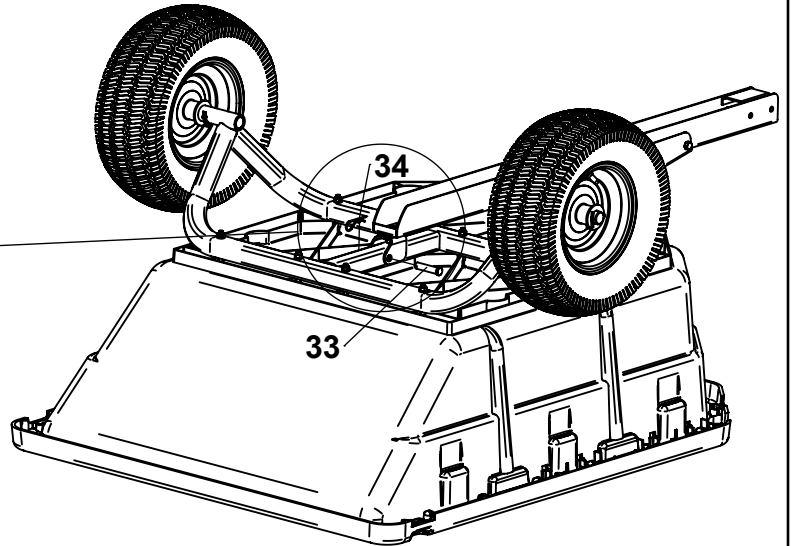
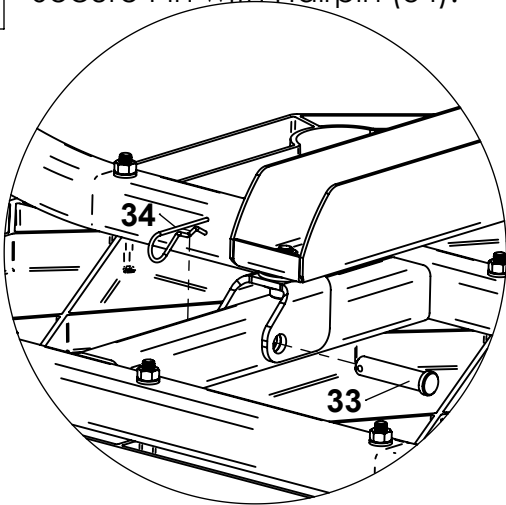

8

Depress Foot Pedal (11), insert Front Support (3) into Drawbar Assembly. When Drawbar is locked in place, flip cart upright onto wheels.

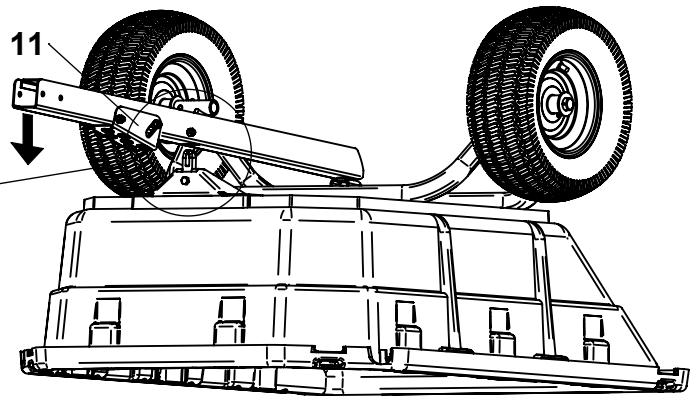
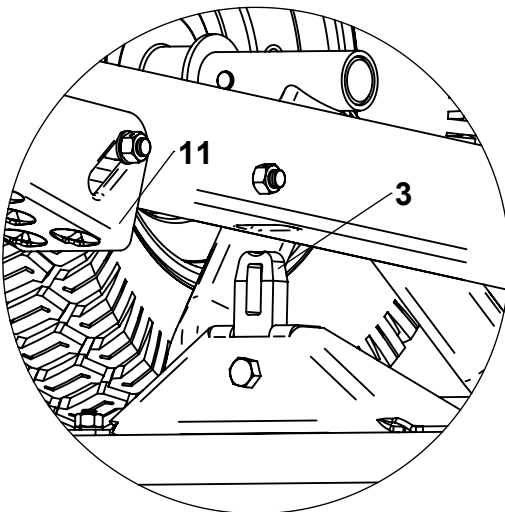

9

Insert preassembled hybrid hitch assembly into Drawbar. Insert Hex Bolts (23) and tighten Nylock Nuts (24). Install Hitch Pin (35) and Hairpin Cotter (34).

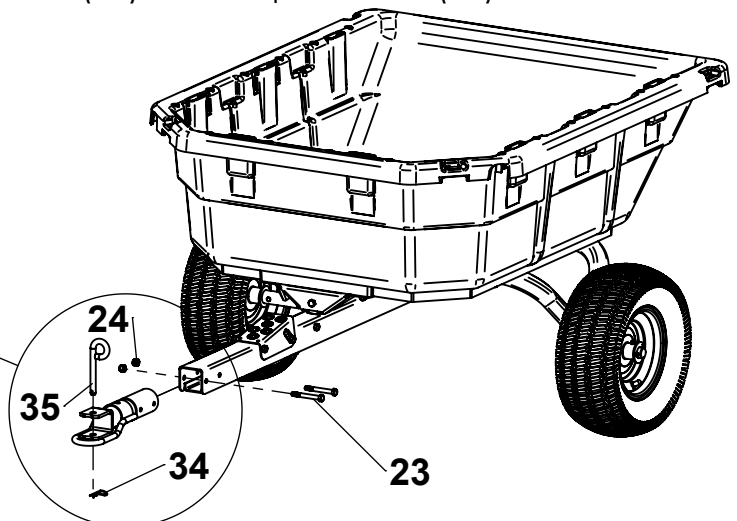
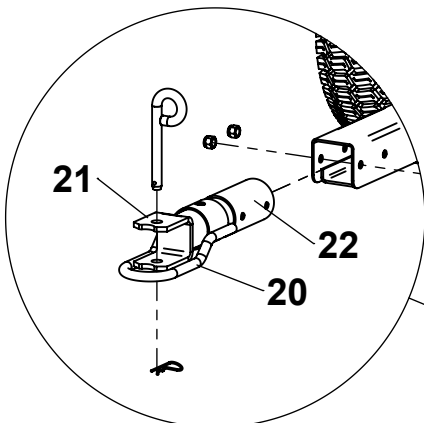

**DO NOT OVERTIGHTEN,
HITCH (21) MUST SPIN FREELY.**

Operating Instructions

Before Using Dump Cart:

1. Apply lithium grease to wheels using grease gun until grease can be seen squeezing out from both sides of the wheel.
2. Check tire pressure and inflate to 24 psi if needed.
3. Read all Safety Rules found on page 1.

How to Use Dump Cart:

1. Attach Dump Cart to your tractor, ATV, or UTV as shown below.
2. Do not exceed 1250 pounds when loading material into the cart body.
3. Distribute the weight of the load as evenly as possible in the cart body for best handling.
4. When hauling heavy loads, verify that your vehicle has adequate towing and braking capacity.
5. Do not exceed 20 miles per hour when towing Dump Cart.

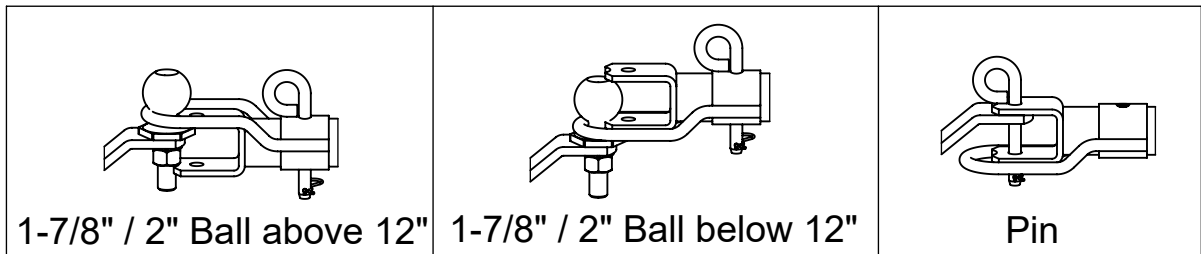

How to Empty Dump Cart:

1. Step down the foot pedal to release the latch mechanism.
2. Lift the body and swivel as desired to guide the material to preferred location.
3. Lift the body entirely and empty material.
4. Lower the body and guide the latch into the drawbar and relatch.

Periodic Maintenance:

- Tighten fasteners as needed before each use
- Check tire pressure before each use
- Grease wheels annually

Do-It-Yourself Accessories

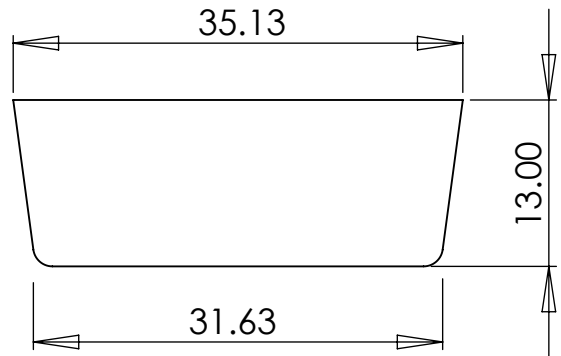
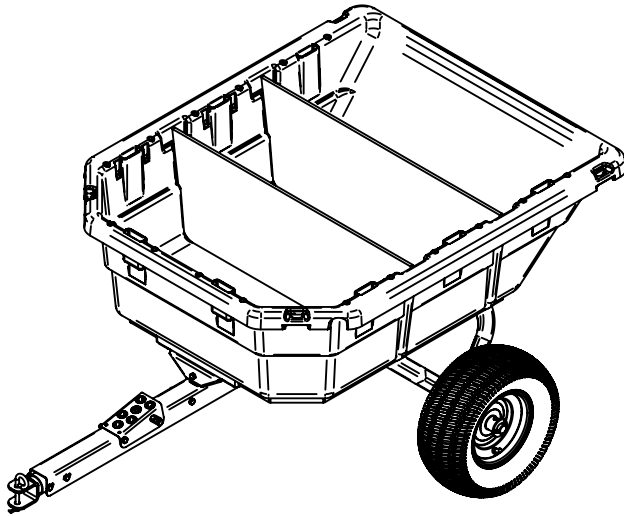

USE 1/2" PLYWOOD

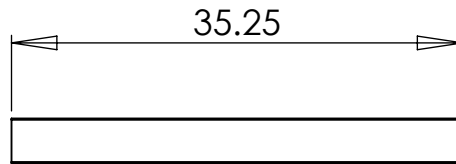
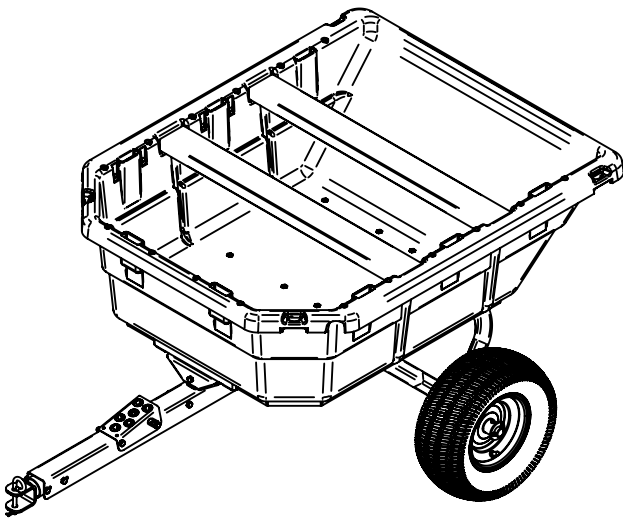

USE STANDARD 2 X 4

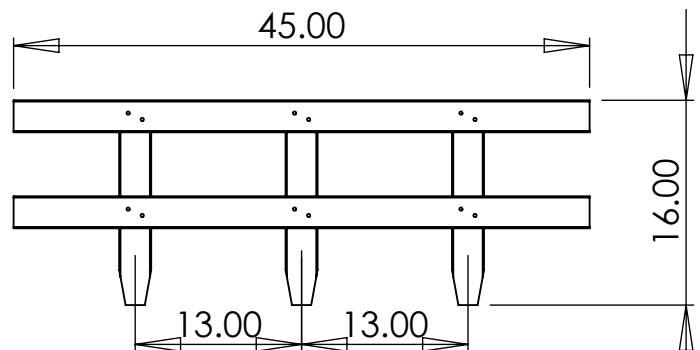
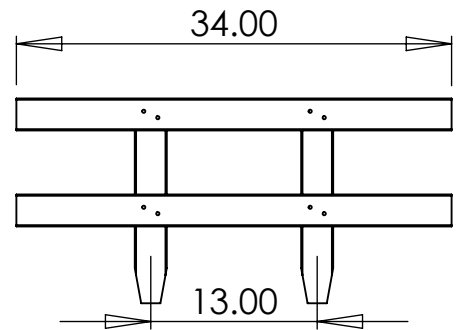
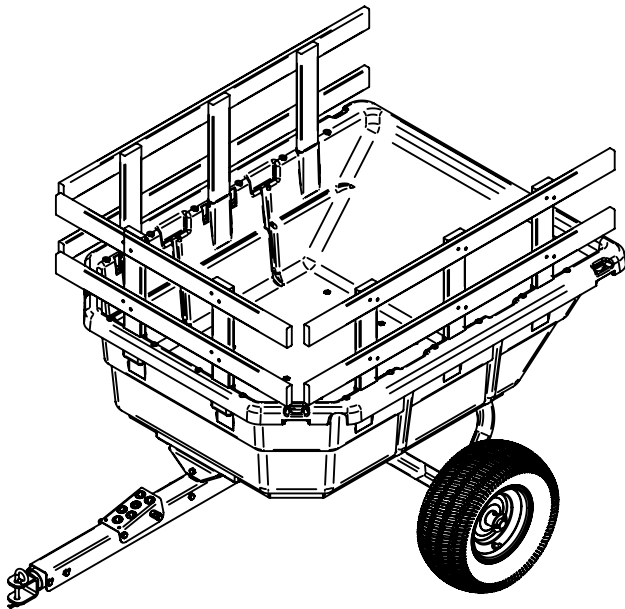

USE NOMINAL GRADE C 1 X 3

Repair Parts

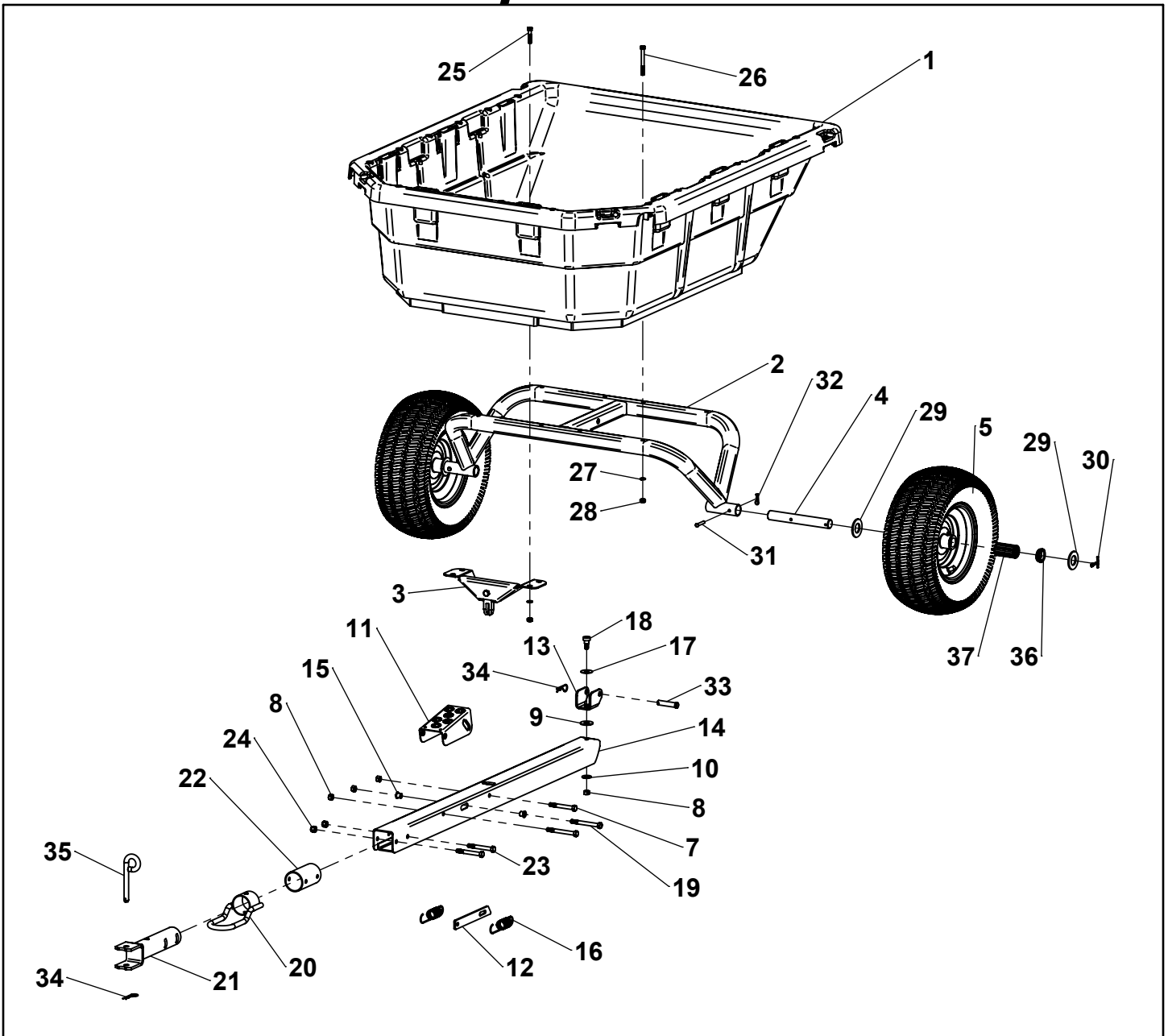

ITEM	PART NO	DESCRIPTION	QTY	ITEM	PART NO	DESCRIPTION	QTY
1	311161	POLY BODY	1	20	6000536-B2	KEEPER WELDMENT	1
2	6000320-B2	UNDERCARRIAGE	1	21	6000534-B2	HYBRID HITCH	1
3	6000311-B2	FRONT SUPPORT ASSEMBLY	1	22	6000379	HITCH BUSHING	1
4	6000367	STUB AXLE	2	23		3/8"-16 X 3" HEX BOLT	2
5	6000301	WHEEL (BEARING/BUSHINGS INC.)	2	24		NYLOCK NUT, 3/8"-16	2
7		3/8"-16 X 3" HEX BOLT	1	25		5/16"-18 X 1-1/2" HEX BOLT	4
8		NYLOCK NUT, 3/8"-16	4	26		5/16"-18 X 3" HEX BOLT	8
9		WASHER, 1/2" FLAT	1	27		5/16" SPLIT LOCKWASHER	12
10		WASHER, 3/8" FLAT	1	28		HEX NUT, 5/16"-18	12
11		FOOT PEDAL	1	29	KIT 6000462	WASHER, 1" SAE	4
12	KIT 6000323-BG	LATCH	1	30		COTTER PIN, 3/16" X 1-1/2"	2
13		CLEVIS, SWIVEL	1	31		CLEVIS PIN, 1/4" X 1-1/2"	2
14		DRAWBAR, WELDED	1	32		HAIRPIN COTTER, 1-3/16"	2
15		3/8" FLANGED BUSHING	2	33		CLEVIS PIN, 1/2" X 2"	1
16		SPRING, LATCH	2	34		HAIRPIN COTTER, 2-5/16"	2
17		SPRING WASHER, 1/2"	1	35		HITCH PIN	1
18		SHOULDER BOLT, 1/2"	1	36	KIT 6000818	1" BEARING RETAINER	4
19		3/8"-16 X 3-1/2" HEX BOLT	2	37		1" ROLLER BEARING	2

OHIOSTEEL
INDUSTRIES

Designed And Tested In Columbus, Ohio

Manufactured In The U.S.A. From Domestic
And Imported Components

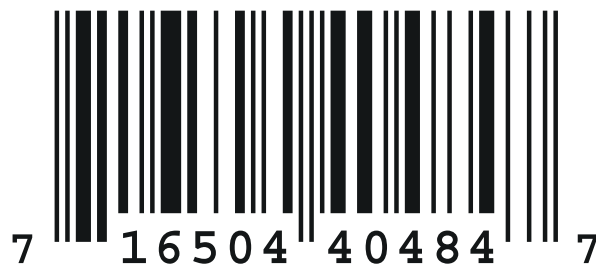

MODEL # 4048P-HYB

2575 Ferris Road Columbus, OH 43224
(800) 652-2321

www.ohiosteel.com

(800) 652-2321